



# Beamsteering and Beam-tracking System for Vehicle-to-vehicle (V2V) Wireless Communication

Dr. Ifana Mahbub

Assistant Professor, Department of Electrical and Computer  
Engineering

University of Texas at Dallas

# Overview

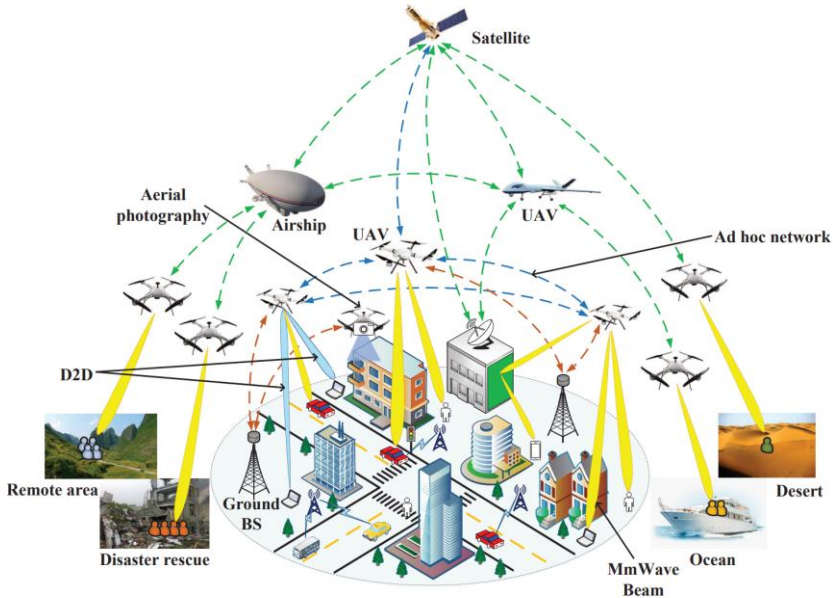

mmW UAV communication, <https://b5g-mints.eu/blog27/>

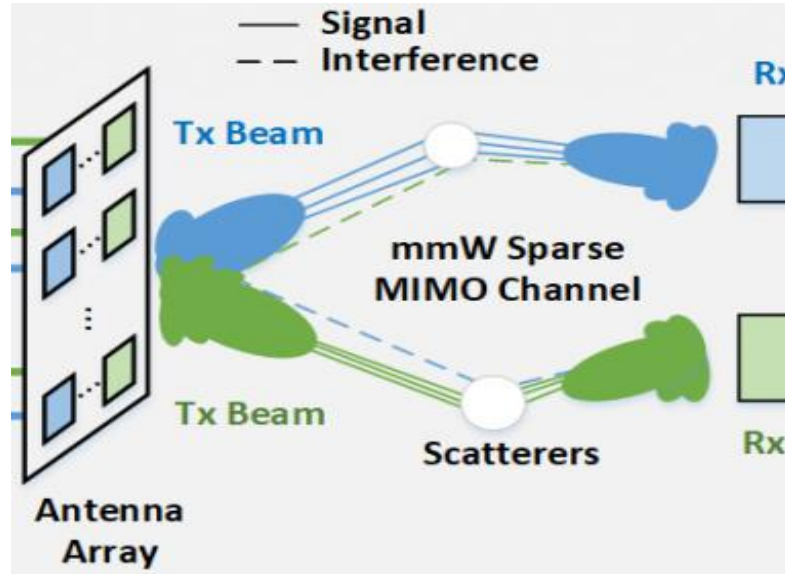

<https://cores.ee.ucla.edu/research/millimeter-wave-transceiver-and-array-architecture-power-aware-tradeoffs-and-design/>

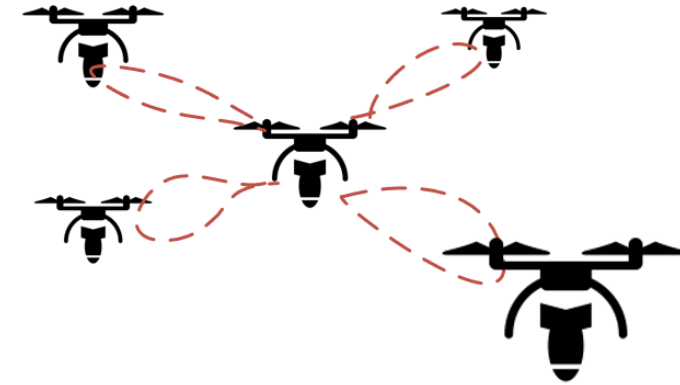

Drone-to-drone communication links

## Some of the challenges in V2V communication include:

- **Interference**
- **Signal Attenuation**
- **Mobility and Dynamic Topology**
- **Limited Bandwidth**
- **Security and Privacy**
- **Energy Consumption**
- **Line-of-Sight (LoS) Issues**
- **Regulatory and Spectrum Allocation**
- **Weather Conditions**

# Challenges

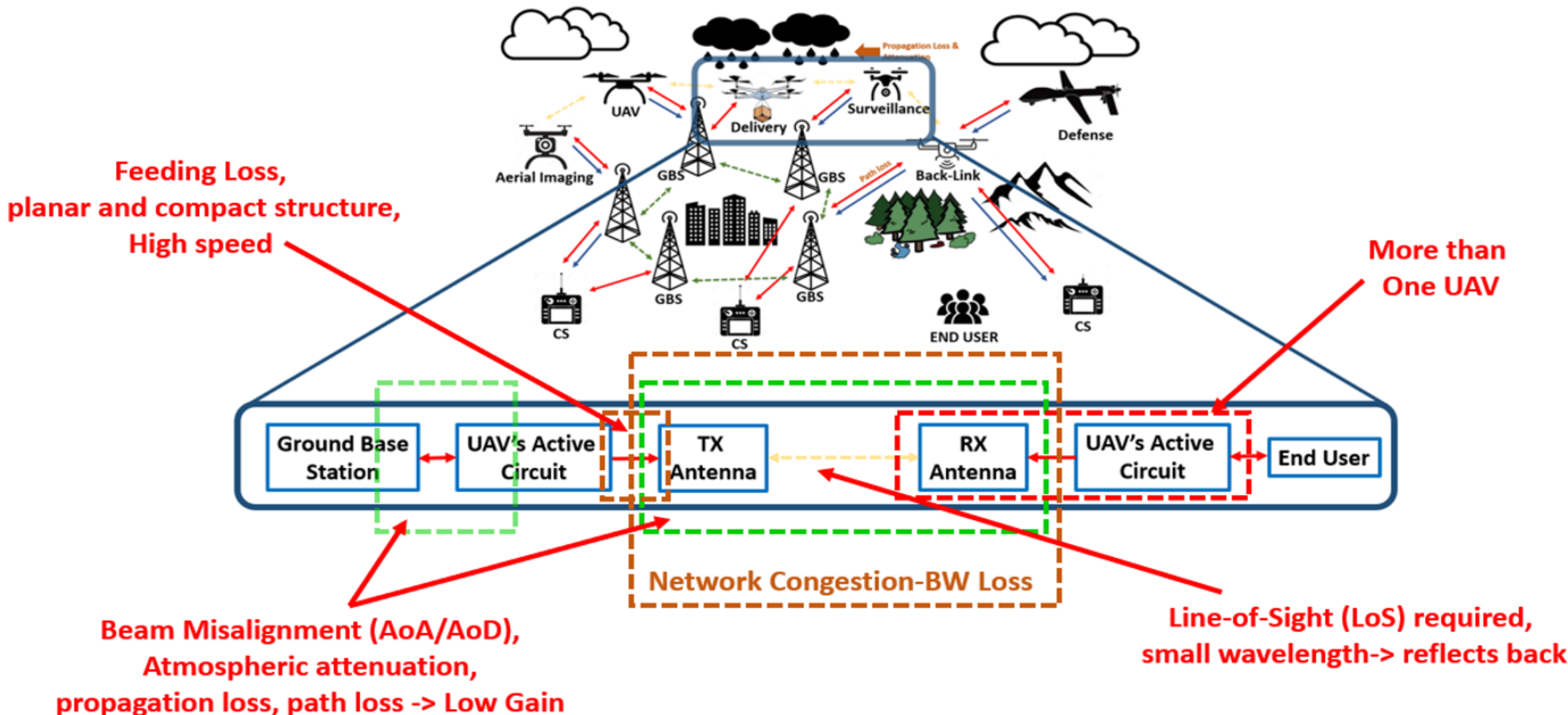

Fig. Distributed system for UAV-to-UAV communication

# RINGS: Mobility-driven Spectrum-Agile Resilient mmWave Communication Links for Unmanned Aerial Vehicle Traffic Management in the Sky

April 2022 – April 2025



CNS 2148178

Collaborators: PI Dr. Namuduri (UNT), Co-PI Dr. Xiang (UNM)

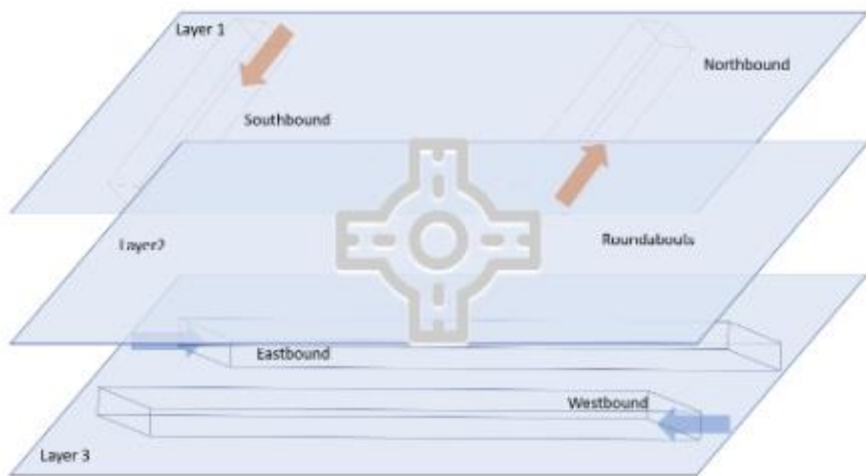
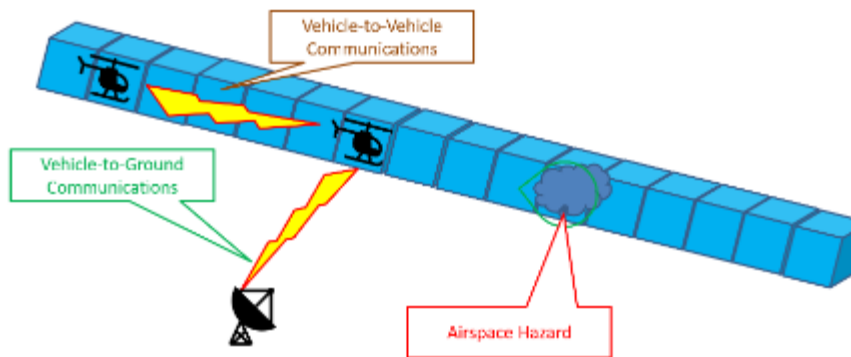
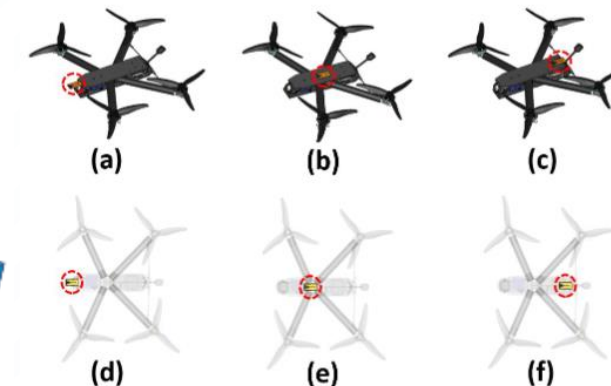

Illustration of an air corridor



Use case for Vehicle-to-Vehicle and Vehicle-to-Ground communication



Antenna positions on drones

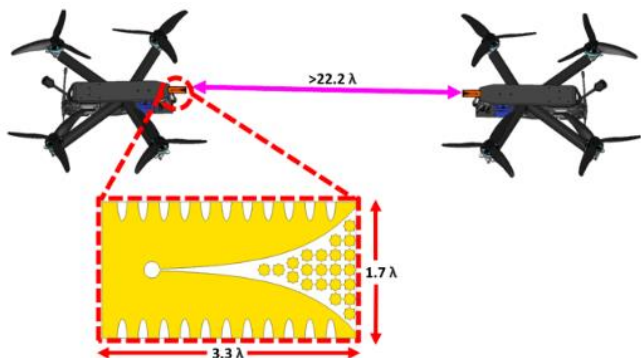

**RQ1:** How to efficiently design the phased-array antenna to achieve the maximum gain, bandwidth, steering angle, and minimum beamwidth?

**RQ2:** How to implement an efficient control algorithms to automatically track and steer the beam through Electrical Beamforming and Mechanical steering?

# Millimeter wave (mmWave) Band

Millimeter wave (mmWave) frequency refers to the range of electromagnetic waves with wavelengths between **1 and 10 millimeters** and corresponding frequencies between **30 and 300 gigahertz (GHz)**.

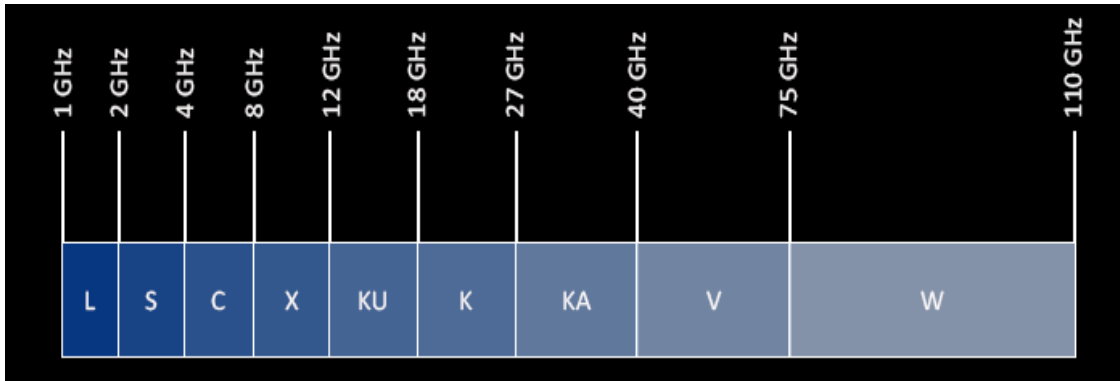

EverythingRF/ frequency bands <https://www.everythingrf.com/community/s-band>

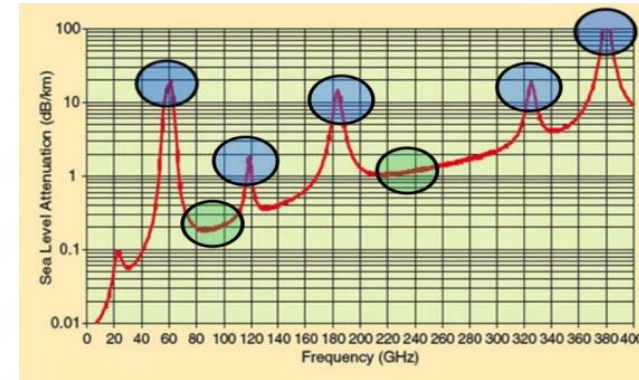
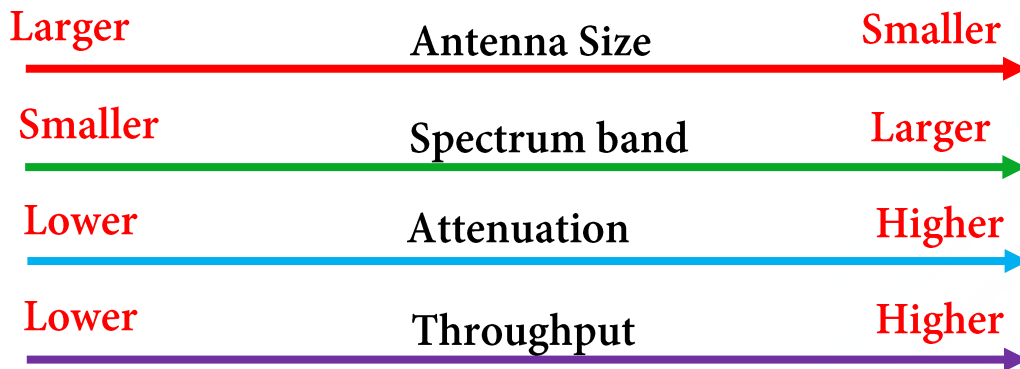

Rappaport et al, doi: 10.1109/JPROC.2011.2143650.

- ✓ When the wavelength is large compared to the size of a raindrop, scattering is predominant.
- ✓ Conversely, when the wavelength is small compared to the raindrop's size, attenuation due to absorption is predominant

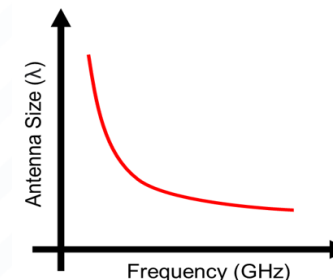

# Millimeter wave (mmWave) Band

## Pros and Cons of Millimeter wave (mmWave) Band Utilization

### Pros

**Wider bandwidth:** Provision to utilize a wider spectrum (30 GHz – 300 GHz).

**High directionality:** mmW band results in smaller apertures, and compact form factor antennas have narrower beam widths, resulting in more directional beam patterns.

**Less congested:** mmW bands are less congested compared to UWB bands.

**Compact form factor:** size reduces as frequency increases.

**Higher data rates:** mmW bands facilitate higher data rates

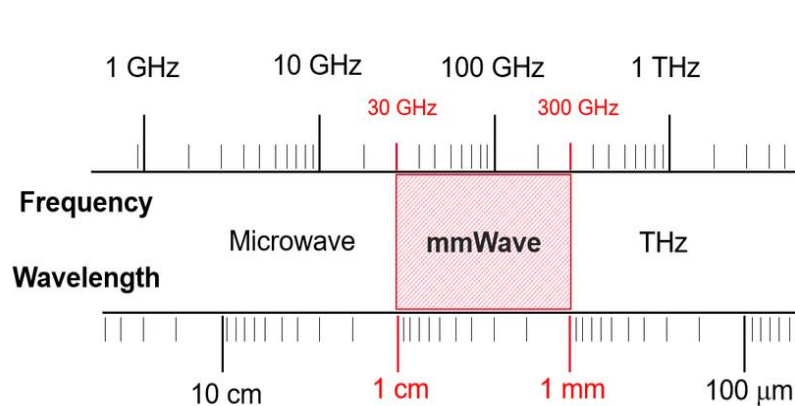

[https://wiki.drobot.com/What\\_is\\_mmWave\\_Millimeter\\_Wave](https://wiki.drobot.com/What_is_mmWave_Millimeter_Wave)

### Cons

#### Higher atmospheric attenuation

Millimeter frequency bands experience high atmospheric attenuation due to peak energy absorption by oxygen and water vapor molecules, reducing signal strength during as EM wave propagation.

#### More prone to external noise

Interference: Higher frequency signals are more prone to interference from other sources.

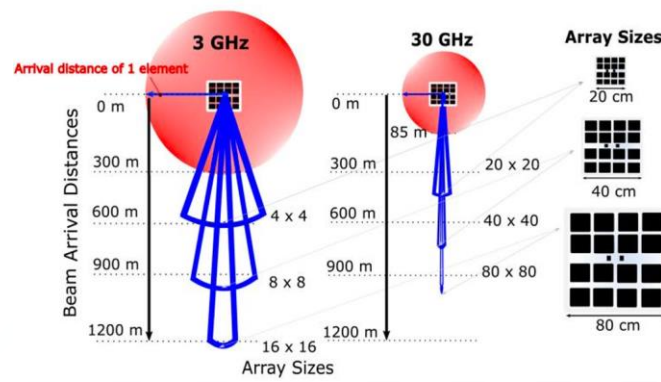

HAL open-source article – comprehensive analysis on mmWave communication systems.

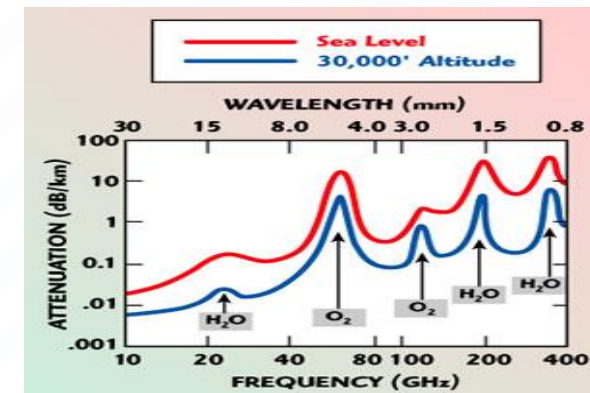

<https://www.microwavejournal.com/articles/663-millimeter-wave-satellite-remote-sensing>

# Millimeter wave (mmWave) Array

Why mmWave antenna arrays?

**High gain:** mmWave antenna arrays results in improved gain.

**High directionality:** of radiation beam can be attained.

**Higher data rates:** mmW antenna arrays facilitate higher data rates.

**Enhanced beam steering:** mmW arrays facilitate efficient beam steering.

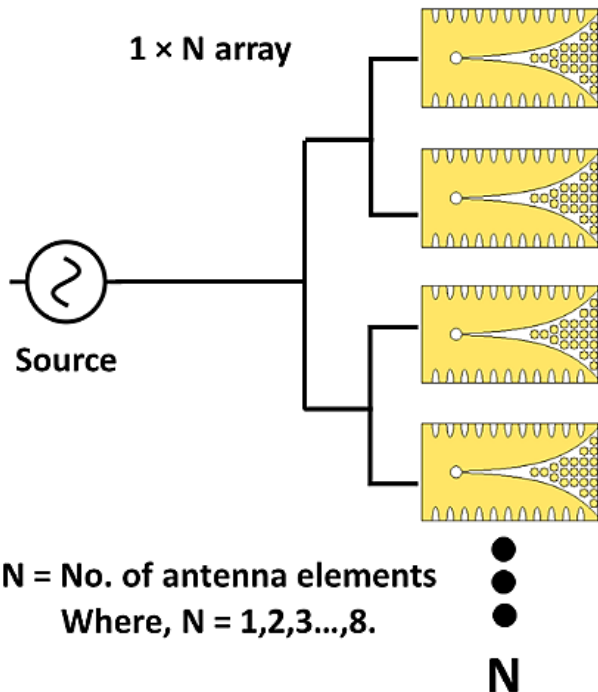

- ❌ Power consumption: Antenna arrays can consume more power.
- ❌ Side lobe and back lobe issues associated with the design complexity.
- ❌ Complexity in feeding network.

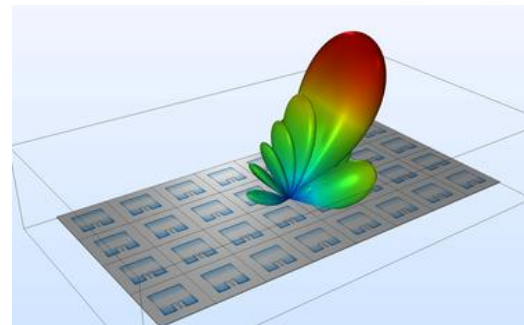

<https://www.comsol.com/model/modeling-of-a-phased-array-antenna-88011>

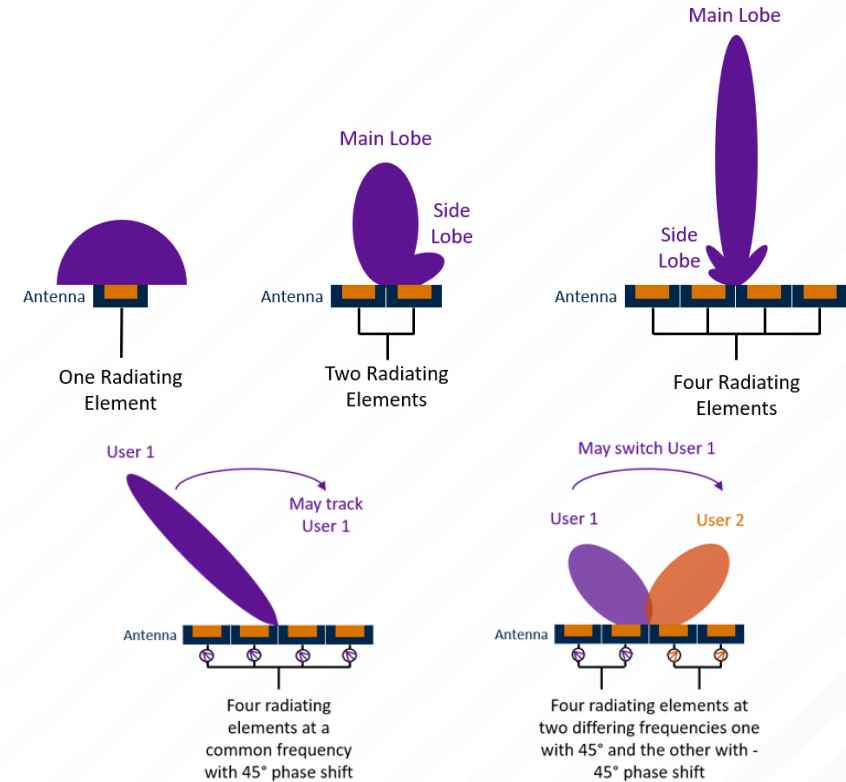

<https://www.metaswitch.com/knowledge-center/reference/>

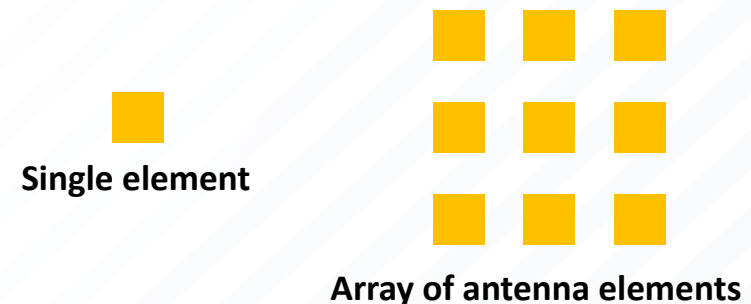

# Electrical Beamsteering for Planar Array

- ❑ In phased array antennas the phase of the signal emanating from the individual elements is fixed.
- ❑ This would give a signal that would be right angles to the axis or plane of the antenna.
- ❑ By controlling and varying the phase of the signals to the antenna elements, it is possible to provide different directive patterns.
- ❑ When a phase difference is applied, the signals will constructively combine at an angle that is different from the perpendicular ( $\theta=90^\circ$ ).

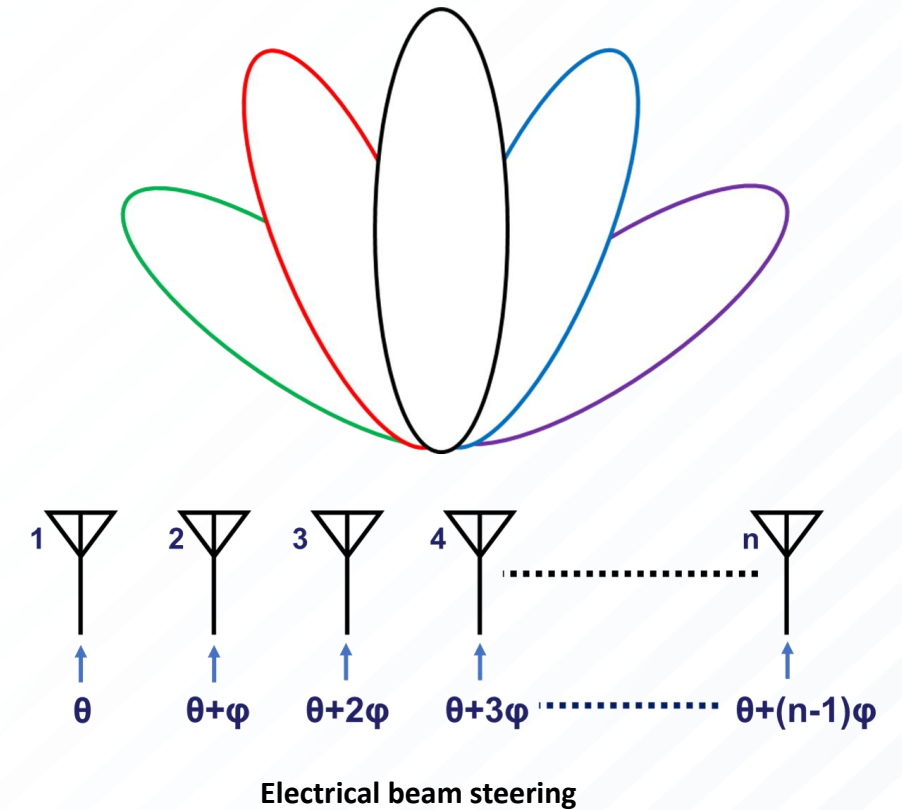



# Electrical Beamsteering for Planar Array

- Radiation Pattern for “n” of antenna element:

$$A(k) = a_0 e^{jkd_0} + a_1 e^{jkd_1} \dots + a_{n-1} e^{jkd(n-1)}$$

- Magnitude
  - Distance between element
  - $d\theta = d \sin\theta \Rightarrow dt = \frac{2\pi d \sin\theta}{\lambda}$
- }  $d < \lambda/2$

Maximum allowed  $d\theta = k \times L_s \times \sqrt{\epsilon_r}$

$$k = \frac{2\pi}{\lambda}$$

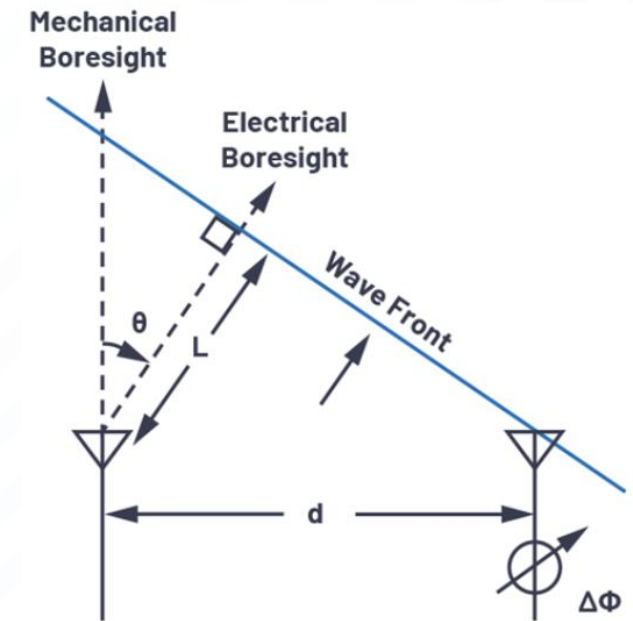

# Electrical Beamsteering for Planar Array

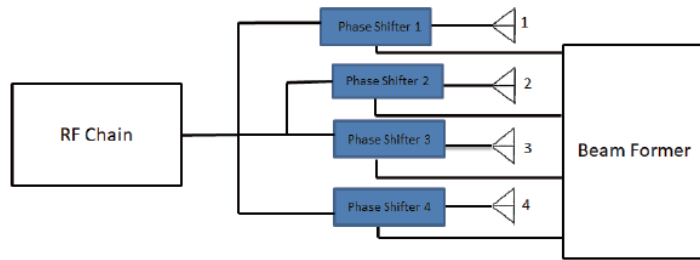

Analog

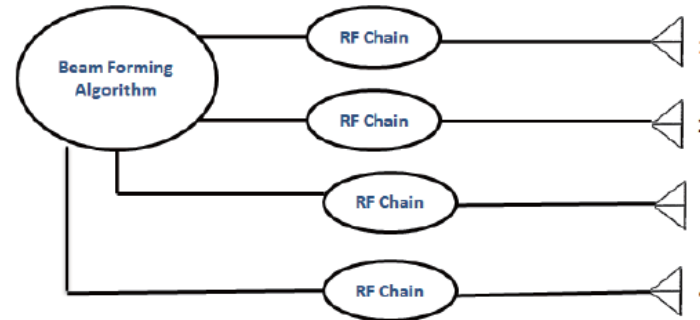

Digital

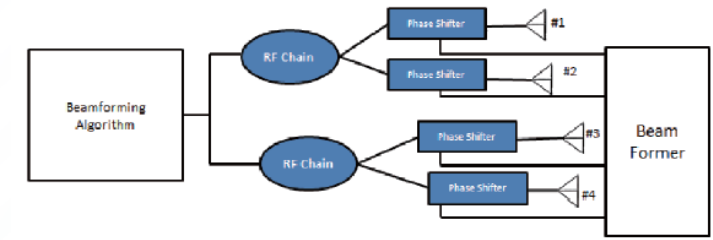

Hybrid

- Cheap
- Low power
- Frequency dependent
- Higher frequency=> BW
- High Insertion loss
- Number of PS => higher IL
- Larger size
- Varactor diode, switched line->FET

- Costly
- Digital Domain -> time delay
- ADCs and DACs for each channel
- Most efficient
- Power consumption
- Wide BW = signal splitting in channels
- Delayed lines

- Reduces the no. of digital phase shifters
- Low loss

# Mechanical Beamsteering for Planar Array

## Mechanical Beam Steering:

- ❑ The antenna is mechanically steered to focus the beam in the desired direction.
- ❑ Planar phased array patch antennas can be rotated along the radiation plane to focus the beam in a desired direction along with electrical steering (e.g. Doppler weather radar).
- ❑ In end-fire antenna arrays, the single elements can be individually rotated to steer the beam mechanically.
- ❑ Vivaldi antennas are suitable end-fire antennas as they have large BW and unidirectional radiation patterns.

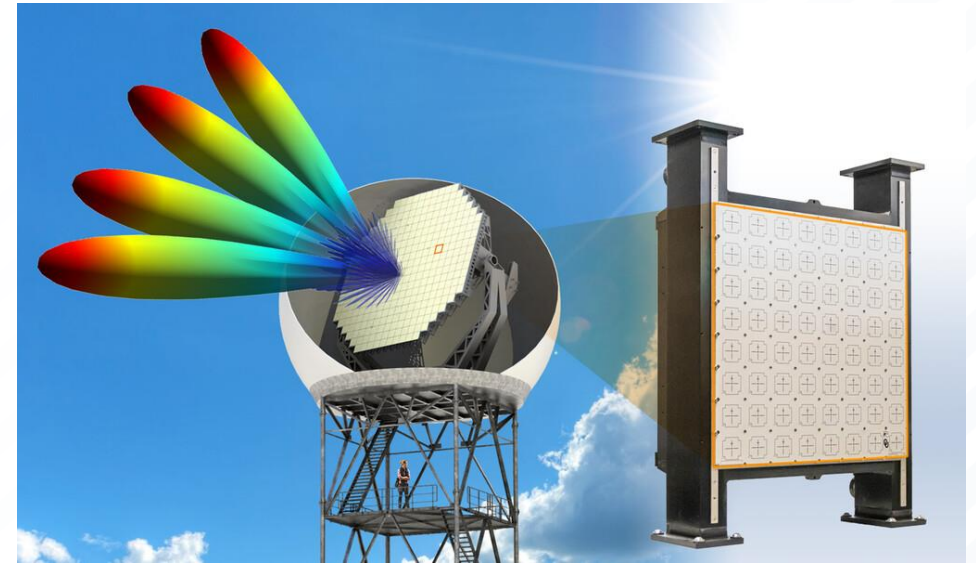

Planner Phased Array Antenna with Mechanical Rotation [1]

[1] R. Palmer et al, "A Primer on Phased Array Radar Technology for the Atmospheric Sciences," in *Bull. Amer. Meteor. Soc.*, vol. 103, issue. 10, pp. 2391-2416, 2022, doi: <https://doi.org/10.1175/BAMS-D-21-0172.1>.

# Tracking Techniques

(1) Target detection, (2) Range of the target, (3) Finding elevation and azimuth angles, (4) Finding Doppler frequency shift

## Angular Tracking

Sequential Lobing

Conical Scanning

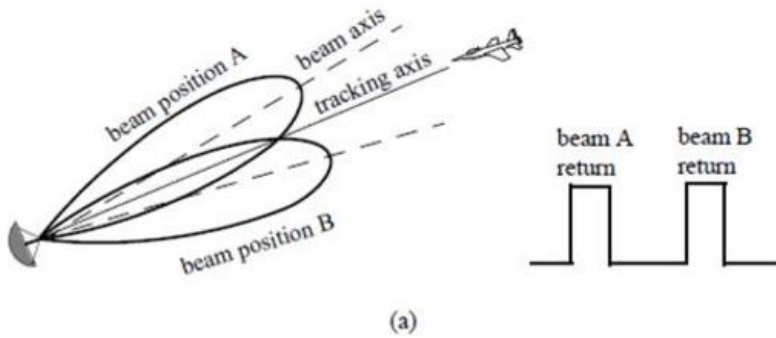

(a)

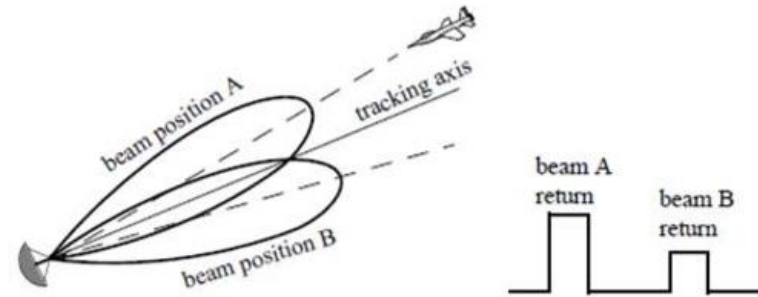

(b)

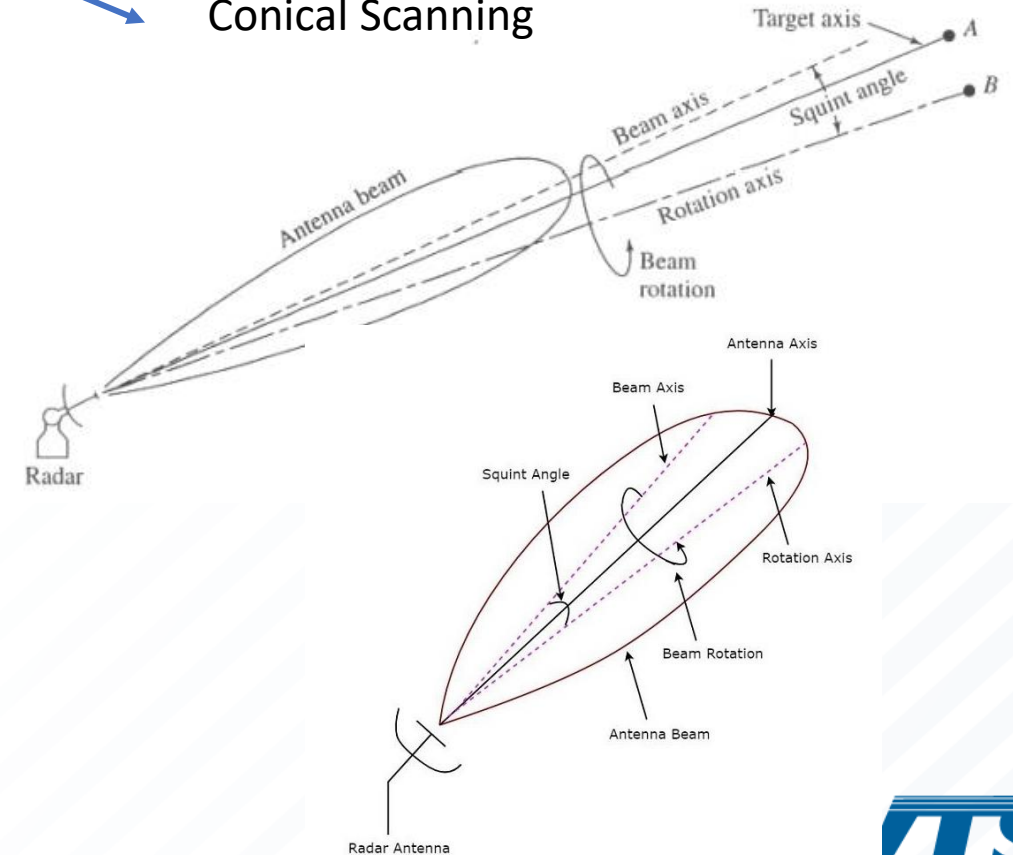
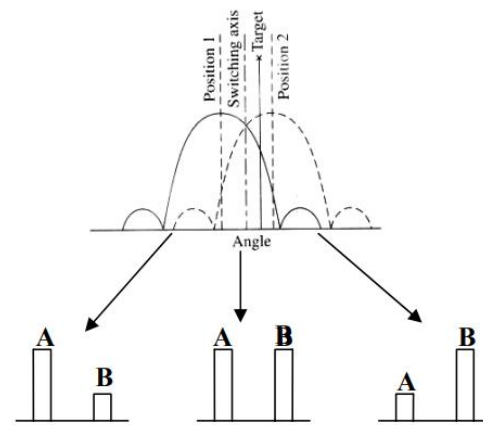

Figures were collected from various sources on the internet.

# Tracking Techniques

## Amplitude Comparison Monopulse Systems

- The monopulse systems use the sum pattern on transmit, whereas the sum and difference patterns are used together on receive.
- The difference in the amplitudes obtained from these two beams (i.e. the difference beam) gives the angular error.
- Phase difference between the sum pattern and the difference pattern provides the direction of the angular error.

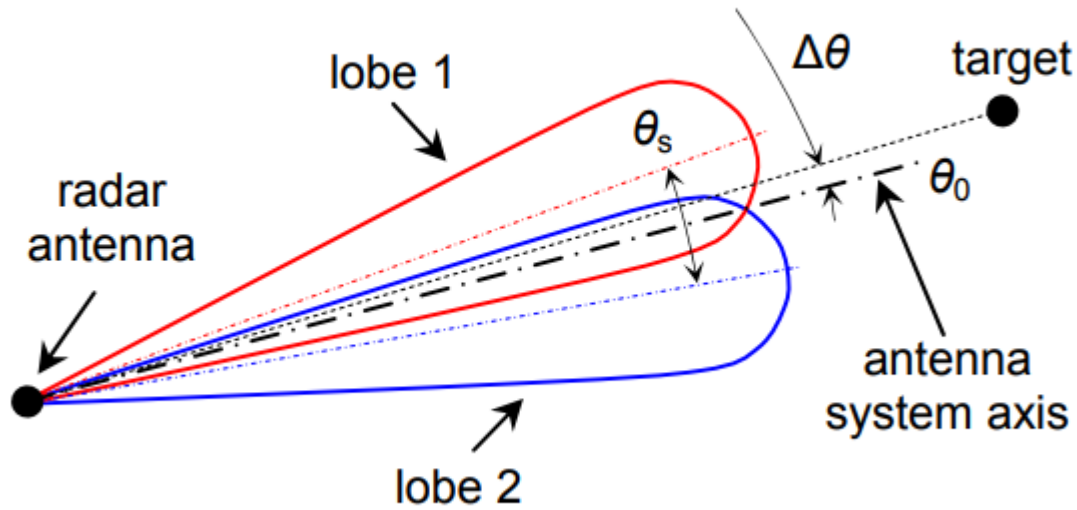

Two squinted antenna beams

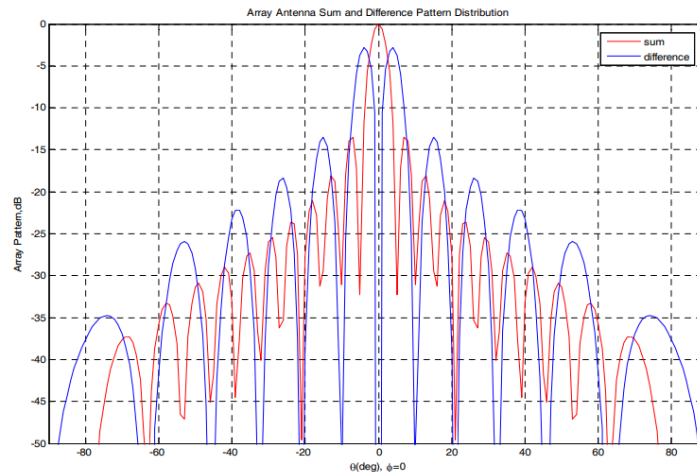

Sum and difference patterns

$$\frac{\Delta}{\Sigma} = \frac{\text{difference voltage}}{\text{sum voltage}}$$

$$\text{Re}\{\Delta / \Sigma\} = \frac{|\Delta|}{|\Sigma|} \cos \delta$$

Figures were collected from various sources on the internet.

# Tracking Techniques

## Amplitude Systems

## Comparison

## Monopulse

## Phase-Comparison Monopulse Systems

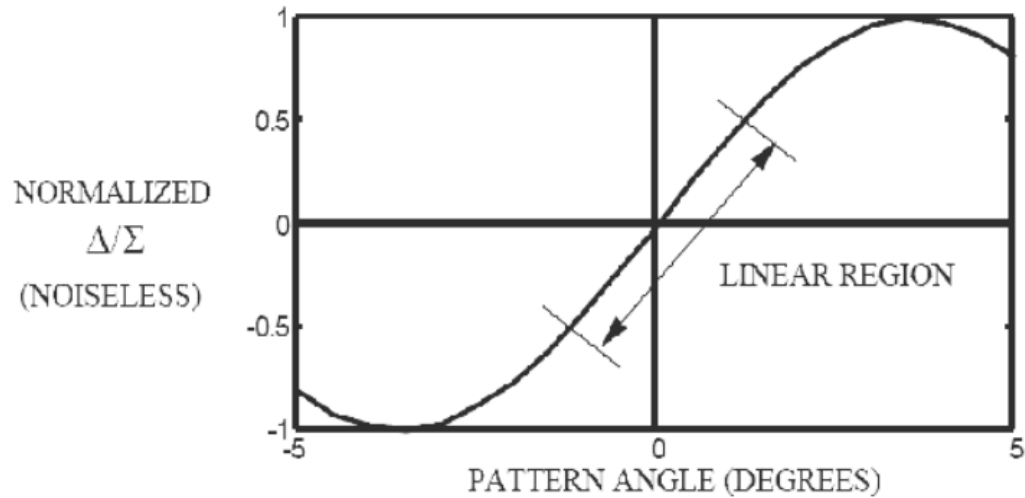

Normalized  $\Delta/\Sigma$  vs. pattern angle

$$\frac{\Delta}{\Sigma} \approx k_s \theta, \quad |\theta| \leq \theta_B / 4$$

$\theta_B$  is the half power beamwidth

$k_s$  is the monopulse slope constant

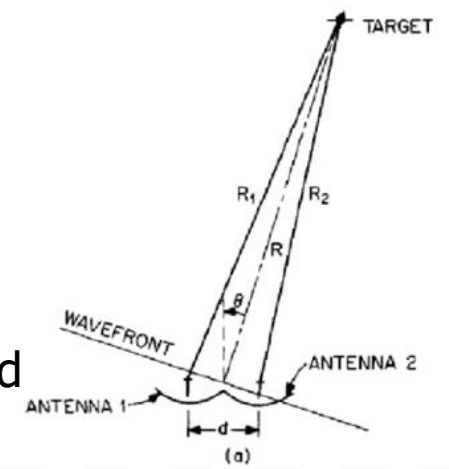
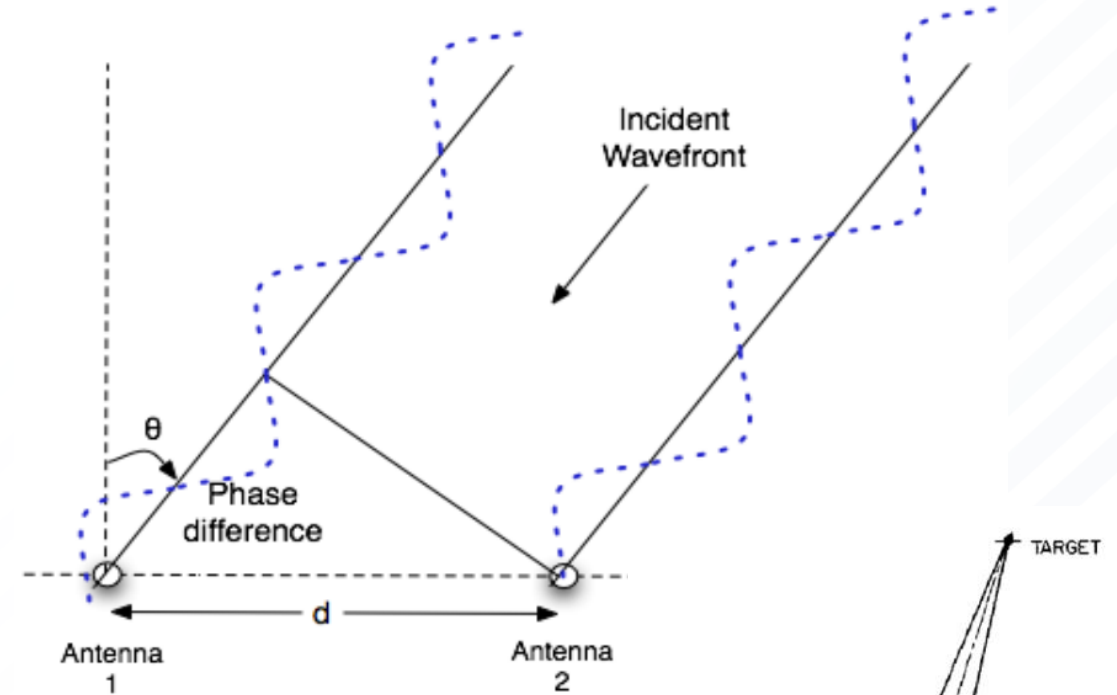

- The two antenna beams point in the same direction.
- The projection of the target on each beam and the amplitudes of the returns from the target received by each of these antennas are the same.

# Highly Compact End-Fire mmWave Vivaldi Antenna for V2V Communication

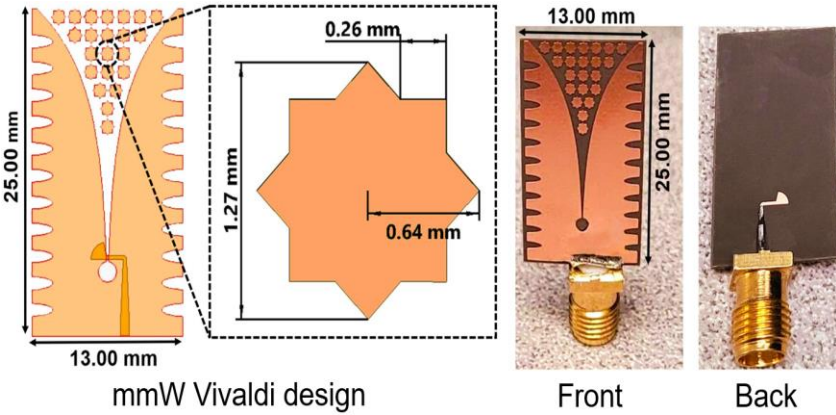

Design architecture

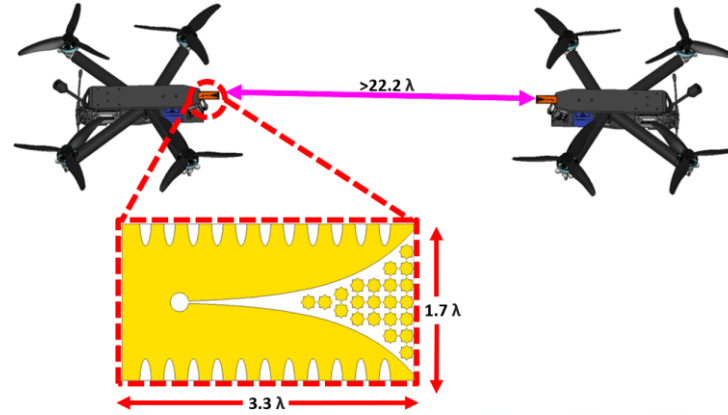

Envisioned case scenario of antennas placed on drones

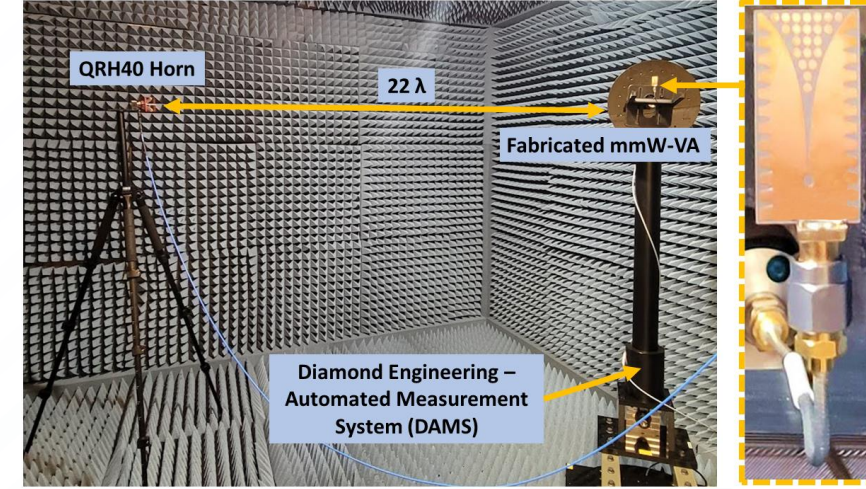

Measurement setup in anechoic chamber

## Key criteria considered for design:

- Highly compact
- Suitable to deployment on drone
- High Gain

## Design specifications:

- Size – 25 mm × 13 mm ( $3.3 \lambda \times 1.7 \lambda$ )
- Realized Gain – 11.4 dBi
- Polarization – Linear polarization
- Half power beam width –  $60^\circ$

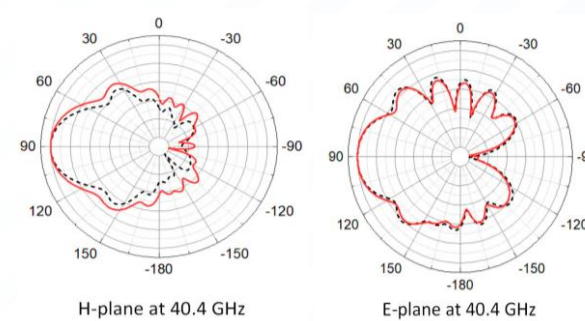
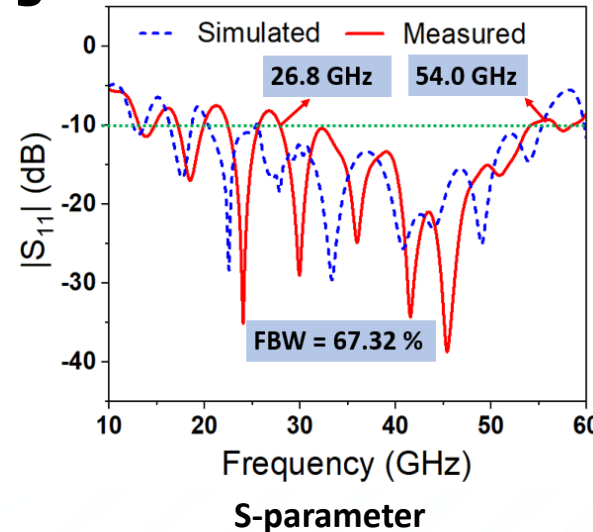

Farfield radiation plots (Normalized)

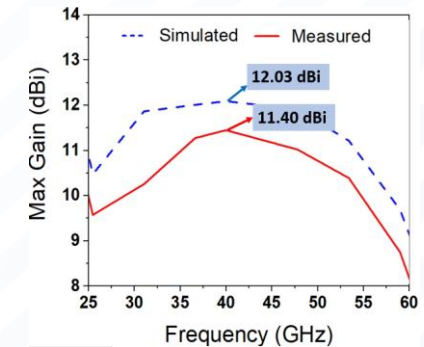

Gain sweep across band

## Measurement results

# Highly Compact End-Fire mmWave Vivaldi Antenna for V2V Communication

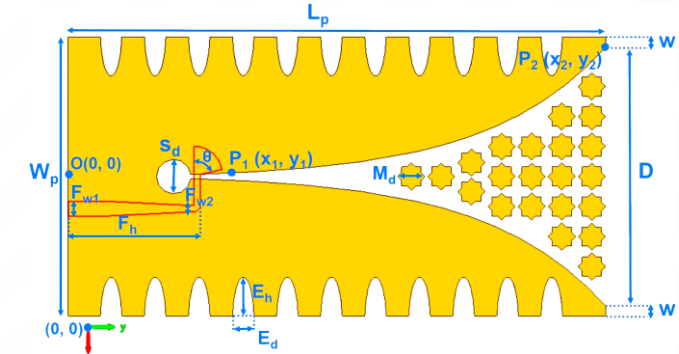
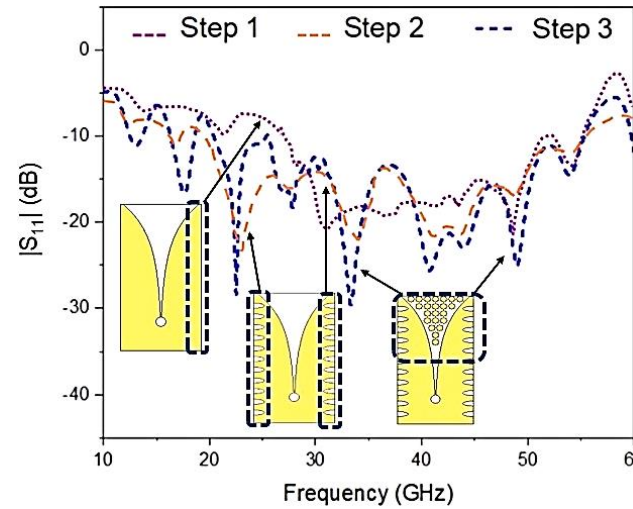
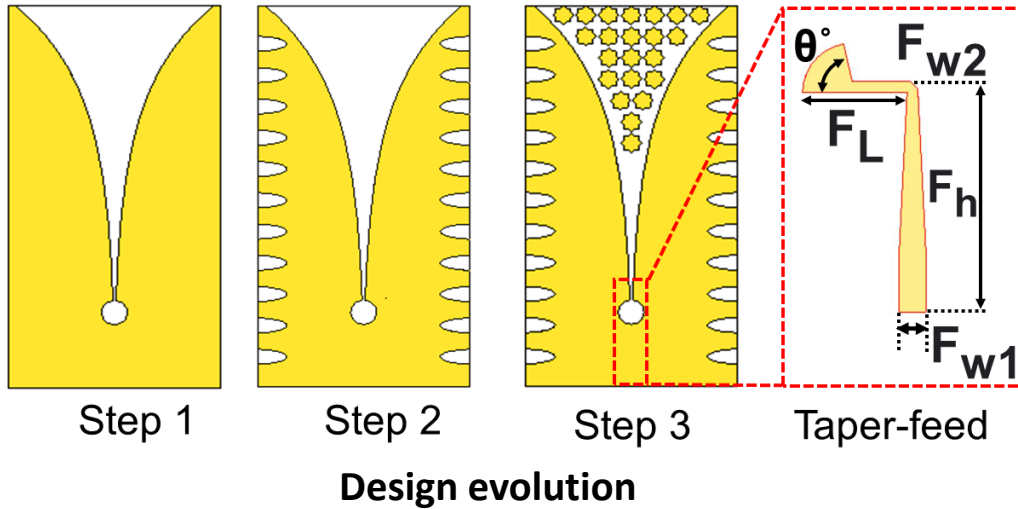

**Antenna dimensions:**  
 $25 \times 13 \times 0.324 \text{ mm}^3$   
**( $3.33\lambda \times 1.73\lambda \times 0.04\lambda$ ).**

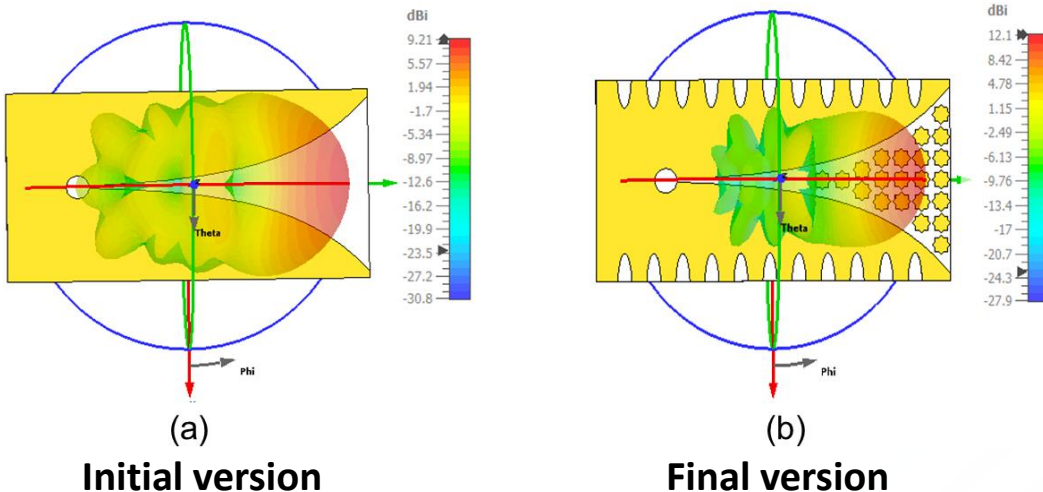

## Specific observations

- ❑ Metal materials utilized between the flares resulted in enhanced gain performance.
  - ❑ Corrugations incorporated in the design results in better S11 performance.
- Wider bandwidth (**>50% FBW**)
  - High gain (**>10 dBi**)
  - Compact and simple design (**<  $3\lambda \times 3\lambda$** )
  - Wide beam steering range (**> $\pm 60$  degrees**)



# Highly Compact End-Fire mmWave Vivaldi Antenna for V2V Communication

## mmWave Vivaldi antenna array analysis

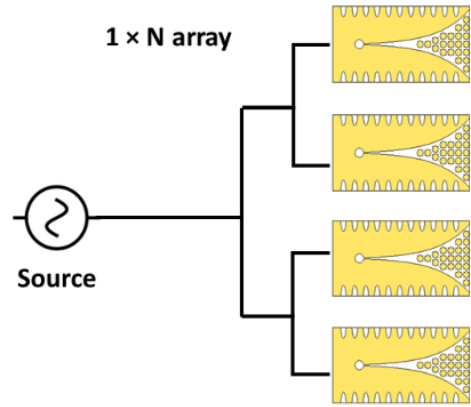

N = No. of antenna elements  
Where, N = 1,2,3...,8.

Schematic of 1 x N mmWave Vivaldi antenna array analysis.

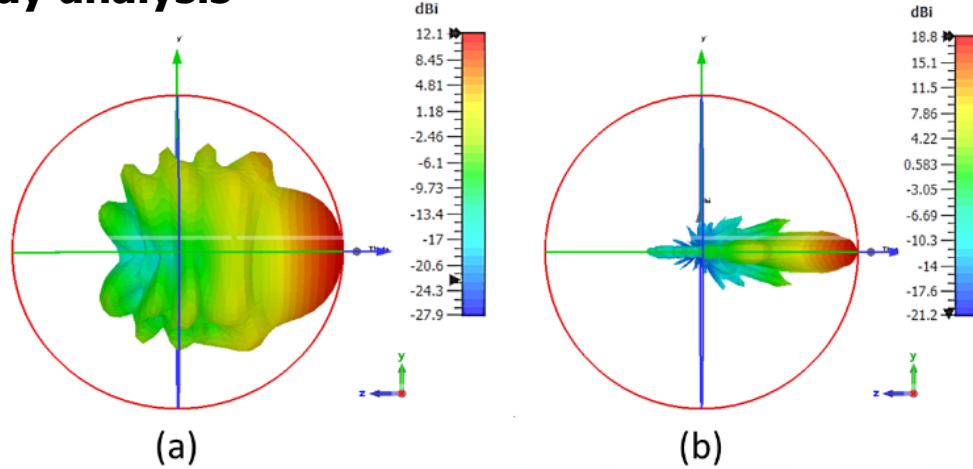

3D radiation absolute gain plots 1 x N mmWave Vivaldi antenna array

CST estimated absolute gain (dBi) values for 1 x N array

Antenna Array	Absolute Gain (dBi)
1x8	18.8
1x7	17.4
1x6	16.8
1x5	16.1
1x4	15.3
1x3	14.5
1x2	13.4
1x1 (Single Element)	12.1

Considering 40 GHz center frequency, the wavelength ( $\lambda$ ) is 0.00749481 m, which is 7.49481 mm, and that of ( $\lambda/2$ ) is 3.747405 mm.



Friss pathloss estimations for 1 to 30 m distance range,

Distance (m)	Friss pathloss (dB)
1	26.88
10	46.88
20	52.90
30	56.42

$$\frac{P_r}{P_t} = G_t G_r \left\{ \frac{\lambda^2}{(4\pi d)^2} \right\} \text{----- Friis Equation}$$

# A Beam-Steerable Compact V-band Leaky Wave Antenna with Surface Integrated Waveguide for Vehicle-to-Vehicle Communication

## 12 x 1 Array – Improved Efficiency

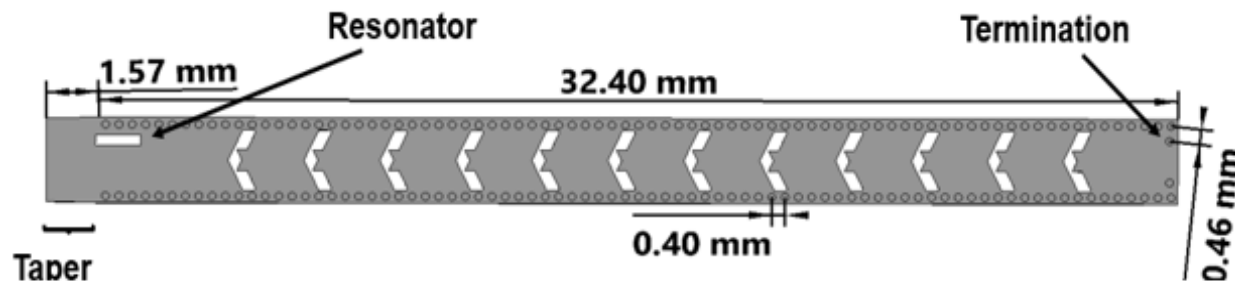

Geometry of the Improved  $12 \times 1$  Array.

- Taper length [6]:

$$L = \frac{n\lambda_g}{4};$$

$$\text{And } \lambda_g = \frac{c}{f\sqrt{\epsilon_r}};$$

Where,  $\lambda_g$  is the guided wavelength and  $f$  is the design frequency, and  $n = 1, 2, 3, \dots$

- 12 x 1 Array Bandwidth: 4.5 GHz (57.5 GHz-62 GHz)

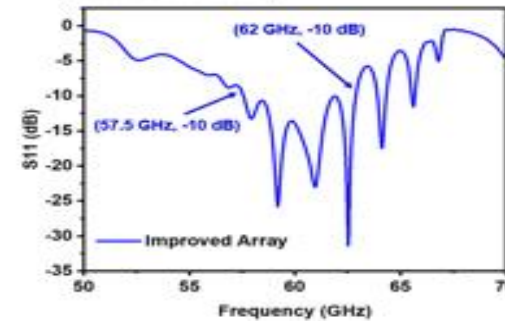

- Max. Gain: 13.43 dBi
- Axial Ratio: 0.29 dB (CP)

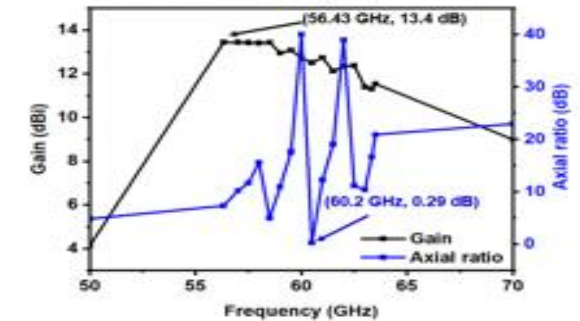

- Scanning Area:  $32^\circ$  (change by 15.8%)

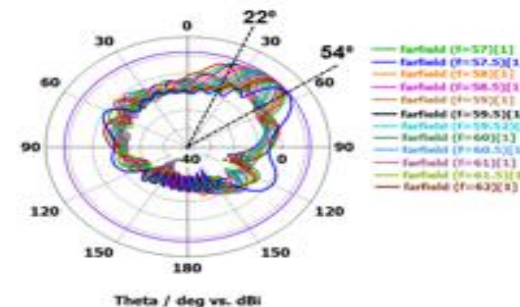

- Total Efficiency: 92.4%
- Radiation Efficiency: 98.8%

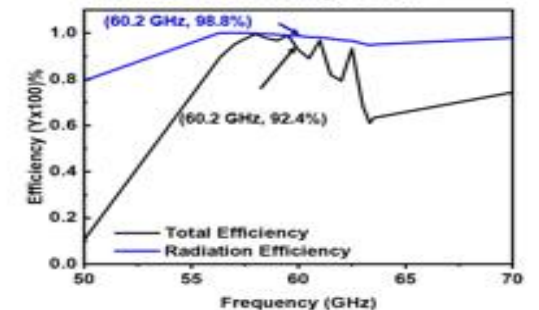

# A Beam-Steerable Compact V-band Leaky Wave Antenna with Surface Integrated Waveguide for Vehicle-to-Vehicle Communication

## Measurement Result



Fabricated LWA

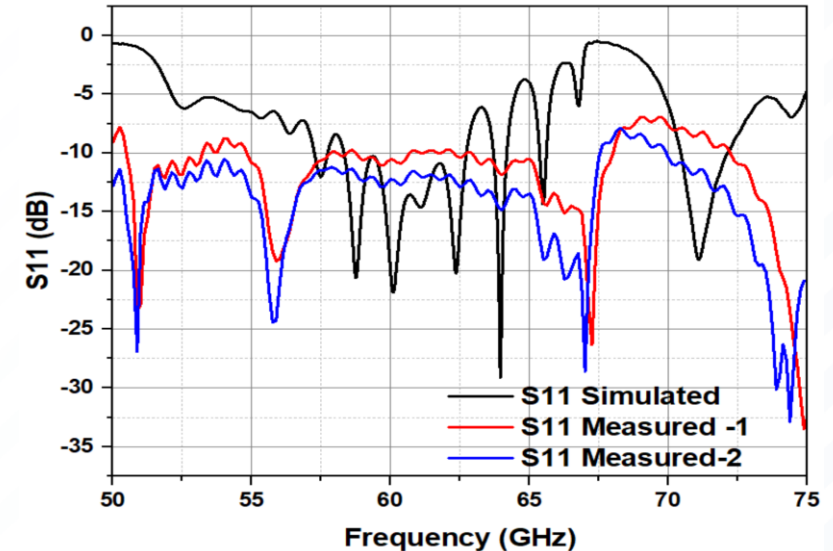
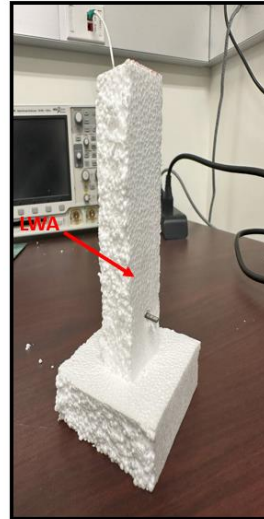
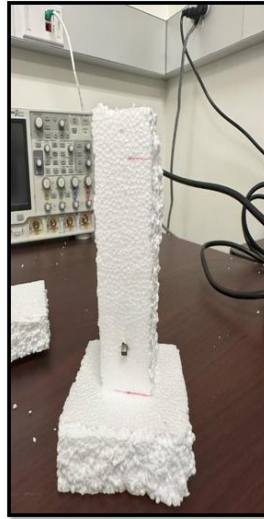
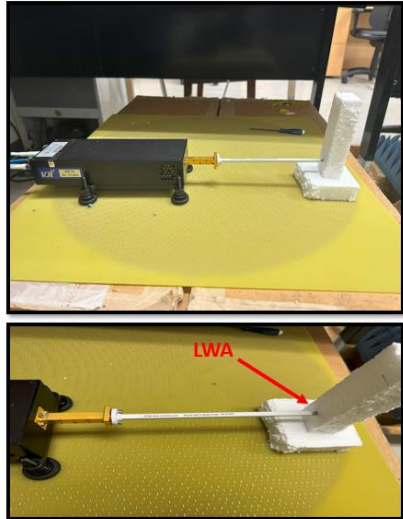

- A compact and highly efficient SIW-based beam-steerable leaky wave antenna operating in the V-band is proposed.
- The designed antenna covers a wide band of frequency ranging from 56.3 GHz to 63.4 GHz and has a frequency scanning angle of  $38^\circ$  within the operating bandwidth.
- The proposed antenna has the smallest dimension of  $3.24 \times 0.2$  cm, making it highly compact and low profile with a side lobe level of -12.7 dB.
- Average half-power angular Beam-width:  $12.1^\circ$

# A Beam-Steerable Compact V-band Leaky Wave Antenna with Surface Integrated Waveguide for Vehicle-to-Vehicle Communication

## 12 x 1 Array – SIW to GCPW

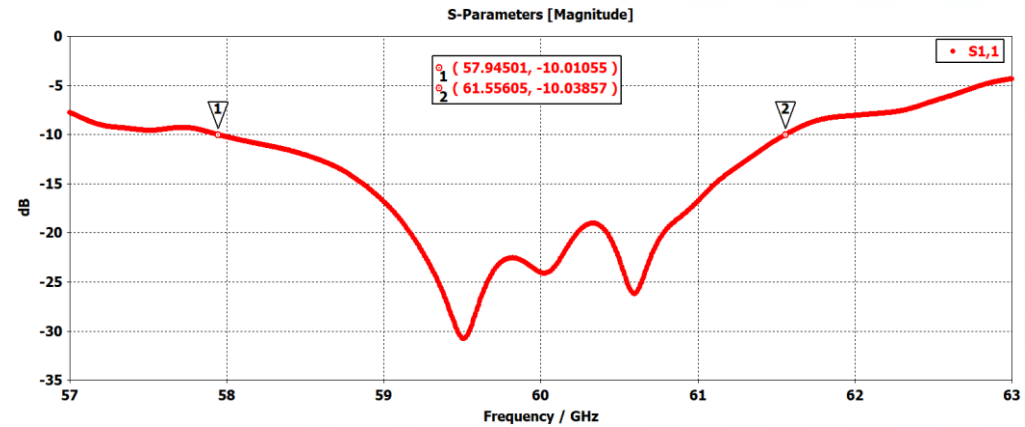
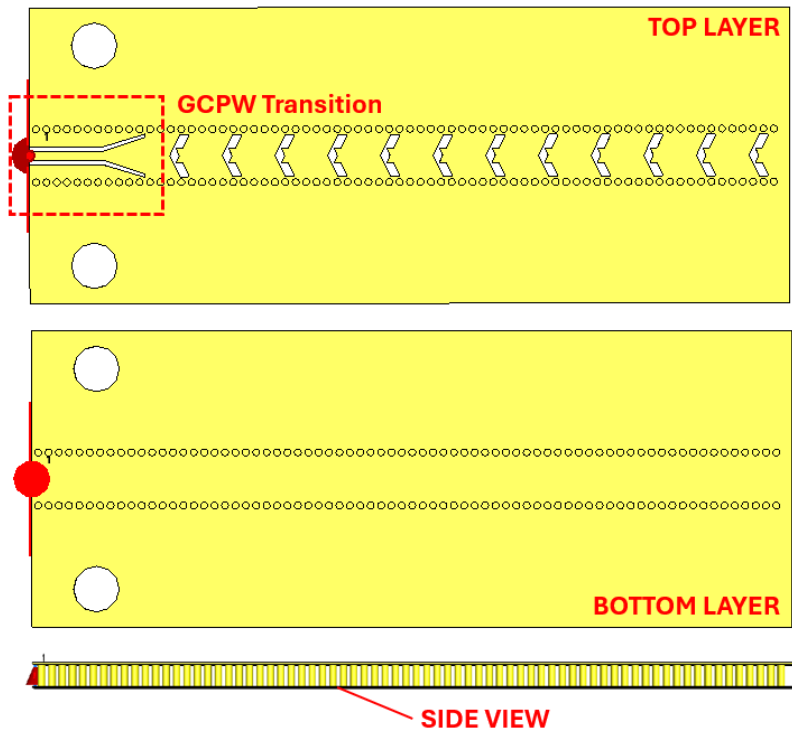

**FBW= 6.05%**

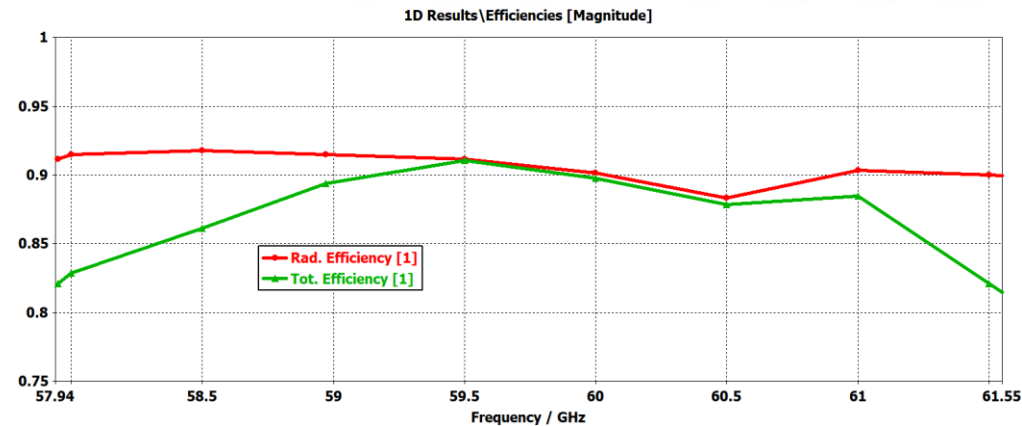

**Rad. Effici.> 89%**  
**Tot. Effici.> 80%**

# A Beam-Steerable Compact V-band Leaky Wave Antenna with Surface Integrated Waveguide for Vehicle-to-Vehicle Communication

## 12 x 1 Array – SIW to GCPW

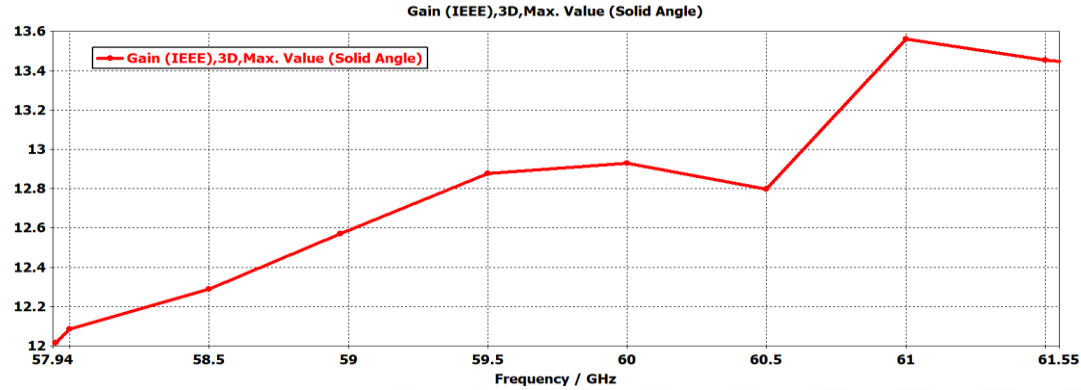
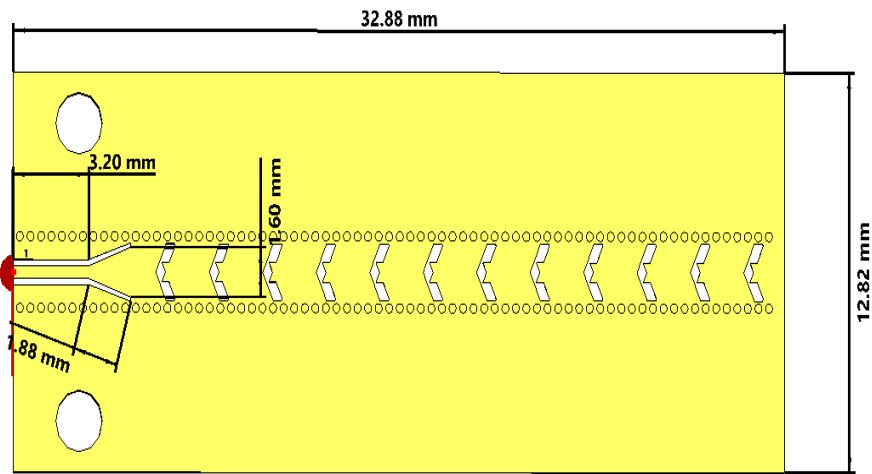

Max. Gain= 13.5 dBi

Beam-Steering= 37°

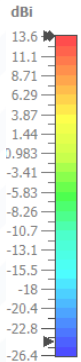
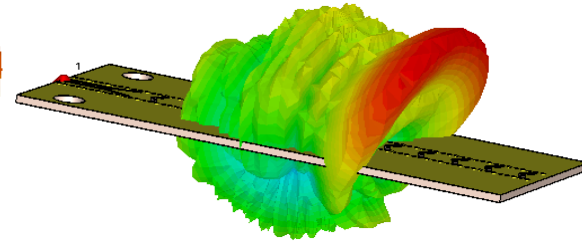
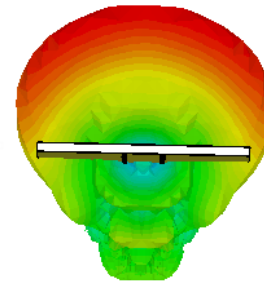
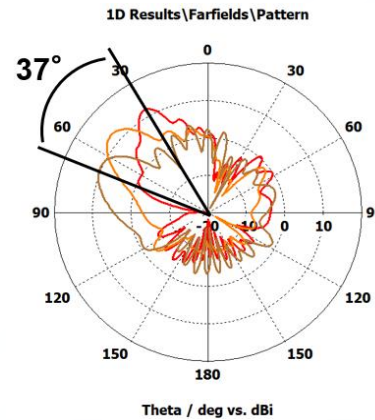

# A High Gain SIW Elliptically Polarized Antenna for Millimeter-Wave Applications

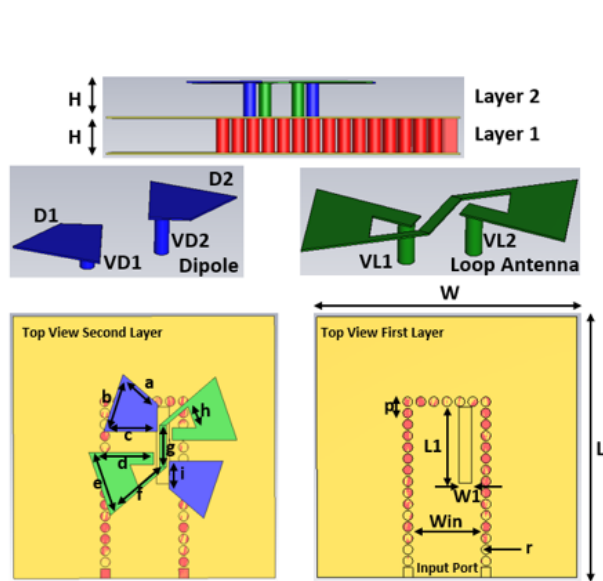

Geometry of the proposed antenna element

Para	Value	Para	Value	Para	Value	Para	Value
a	1.38	e	2.02	i	0.83	W1	0.4
b	1.83	f	2.24	p	0.35	Win	2.4
c	1.63	g	1.28	r	0.15	L	8
d	1.97	h	0.69	L1	2.34	W	8

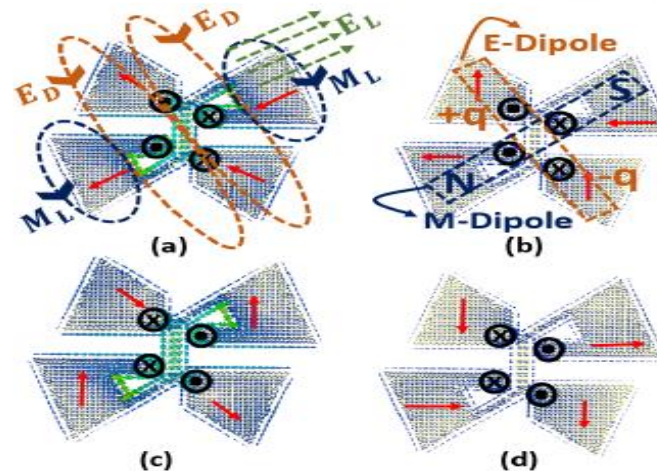
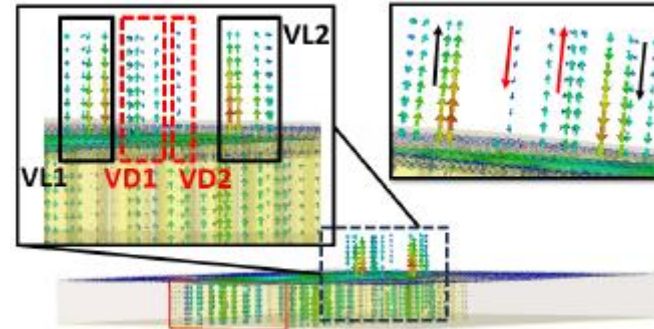

Antenna Bandwidth: **7 GHz / 24.9%**  
(48.5 GHz-62.3 GHz)

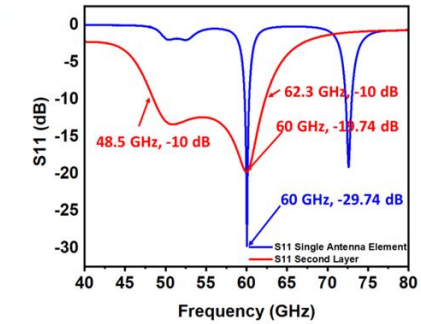

Axial Ratio: **6.99 dB (EP)**

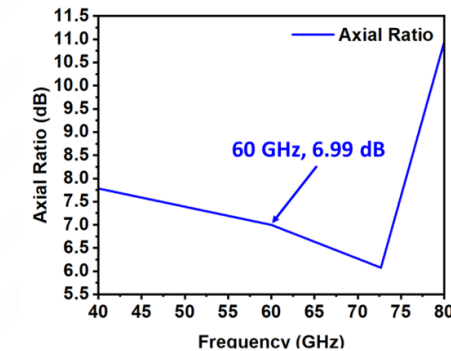

Max. Gain: **8.34 dBi**

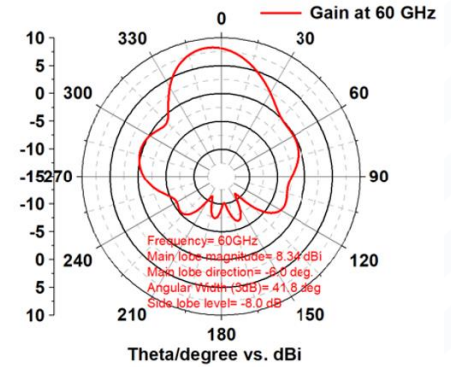

Max. Gain: **8.34 dBi**

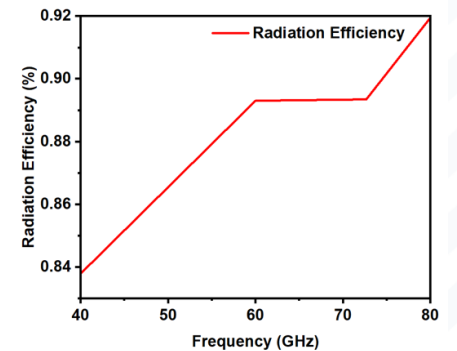

P. Sah and I. Mahbub, "A High Gain SIW Elliptically Polarized Antenna for Millimeter-Wave Applications," 2023 IEEE International Symposium on Antennas and Propagation and USNC-URSI Radio Science Meeting (USNC-URSI), Portland, OR, USA, 2023, pp. 1903-1904, doi: 10.1109/USNC-URSI52151.2023.10237514.

# A High Gain SIW Elliptically Polarized Antenna for Millimeter-Wave Applications

## Measurement Result

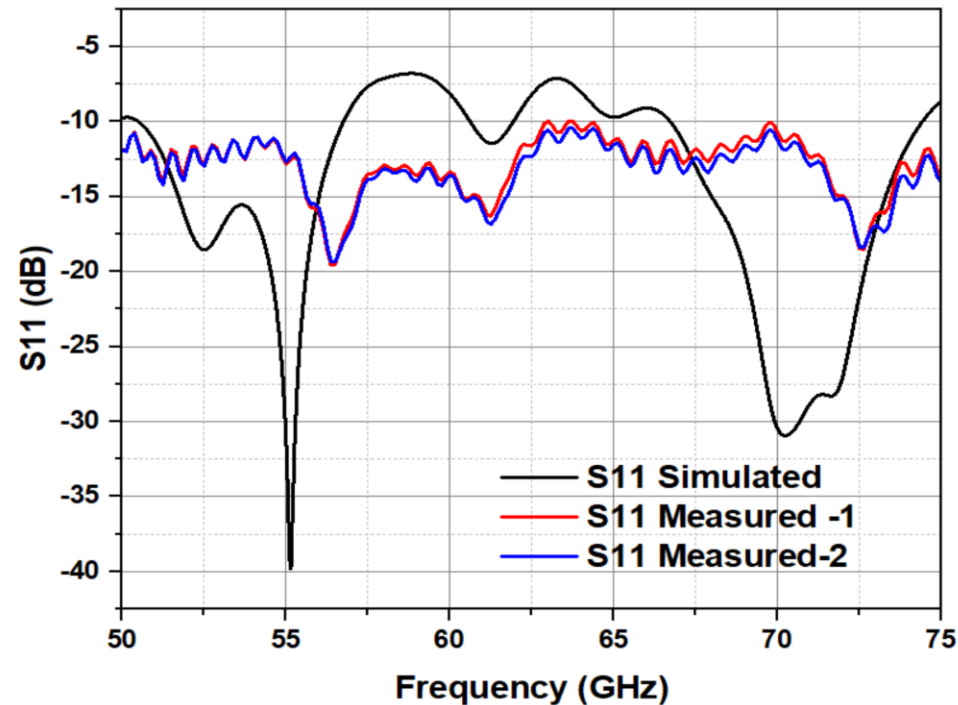
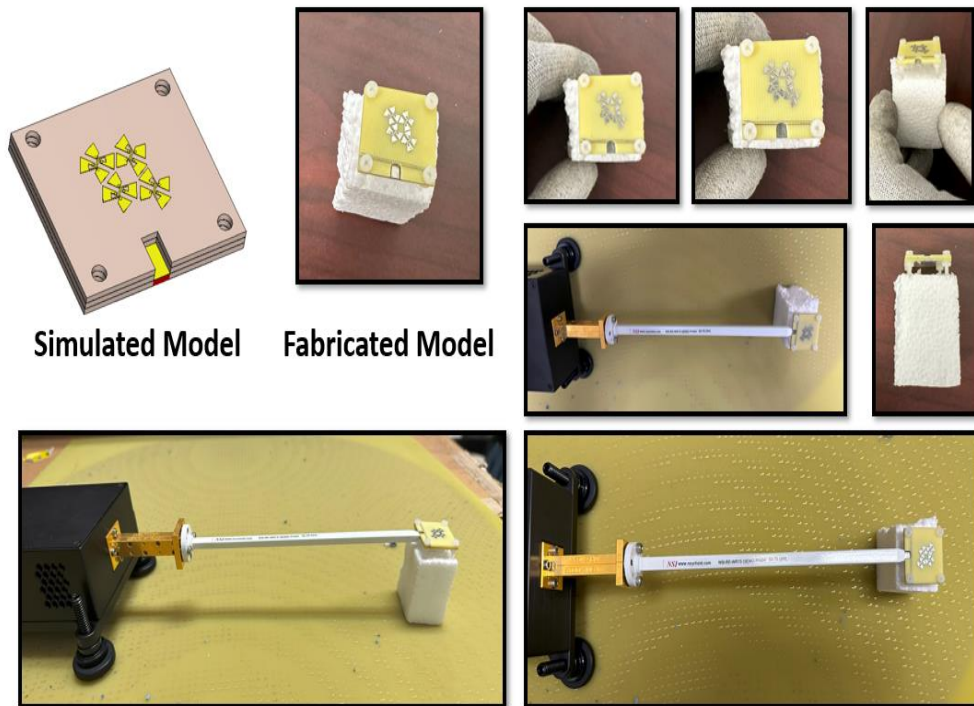

- Stable gain: 8.34 dBi
- BW: 48.5-62.3 GHz
- Side lobe Level: - 8 dB
- Efficiency: > 86%

# A High Gain SIW Elliptically Polarized Antenna for Millimeter-Wave Applications

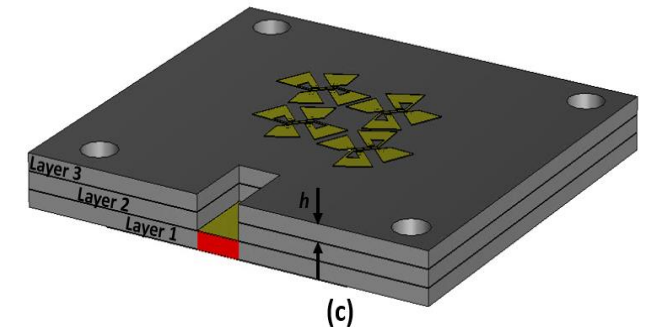
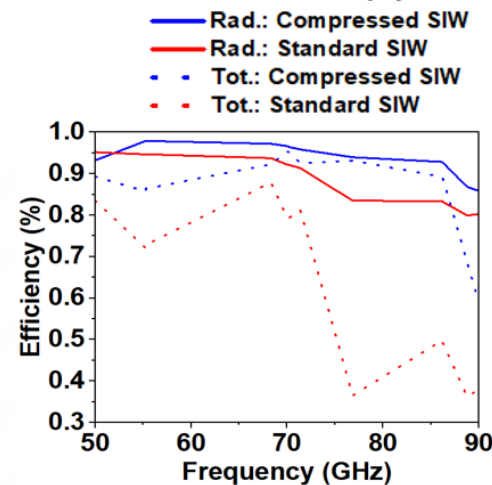
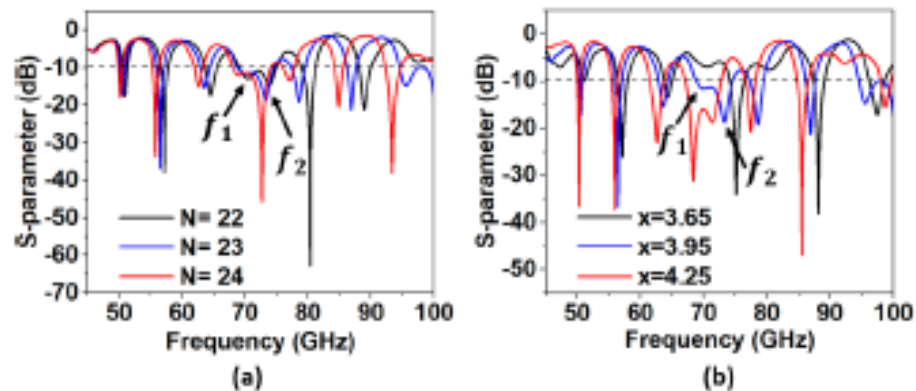
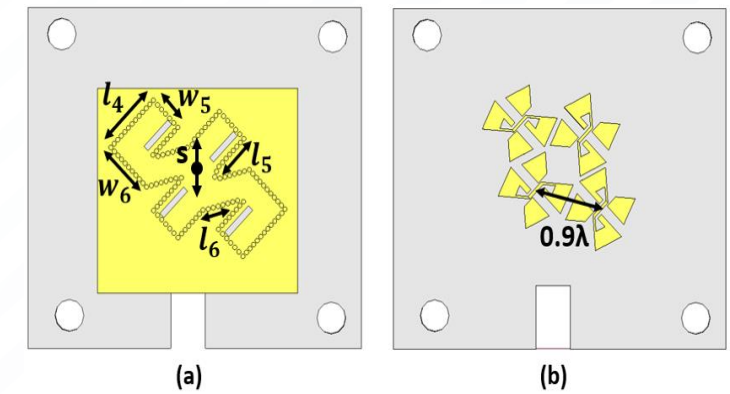
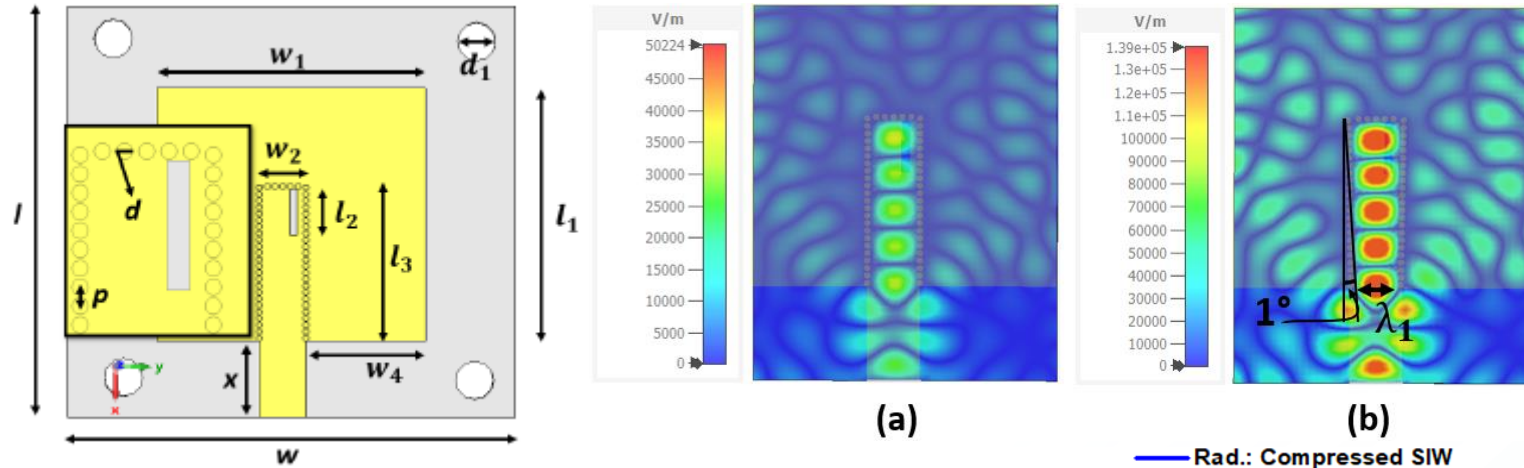

Fig. 2 x 2 Array



# A High Gain SIW Elliptically Polarized Antenna for Millimeter-Wave Applications

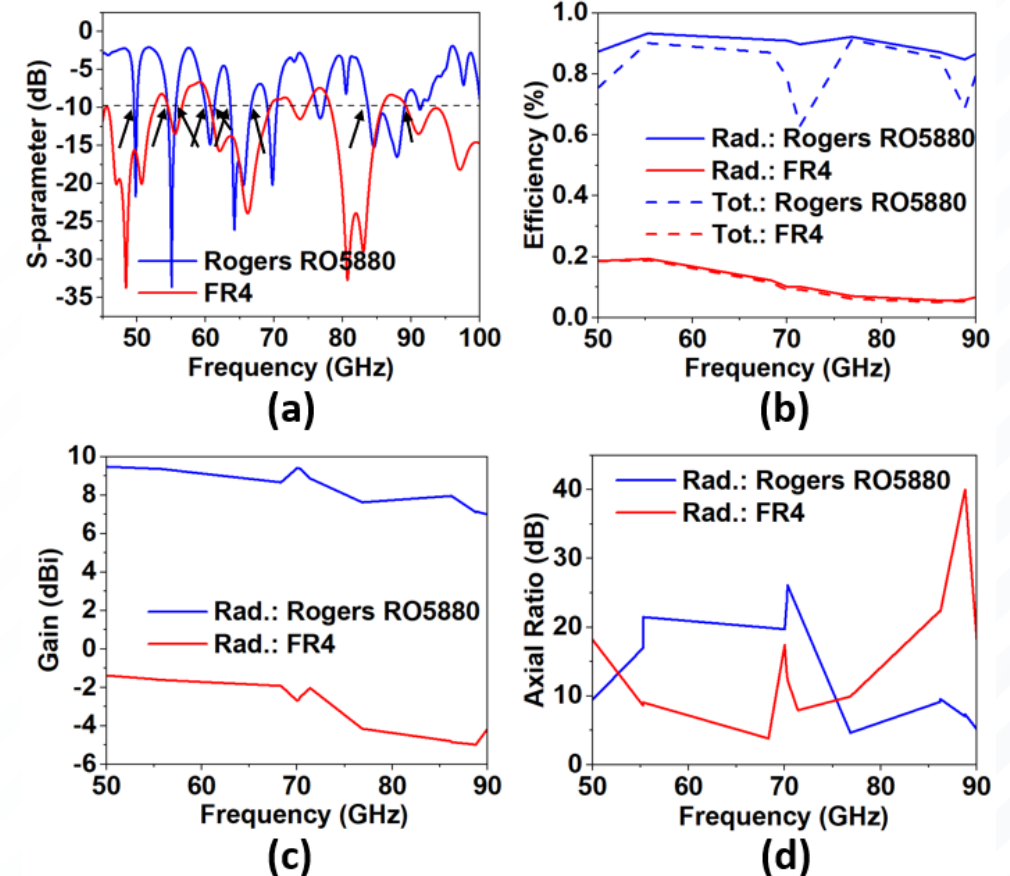
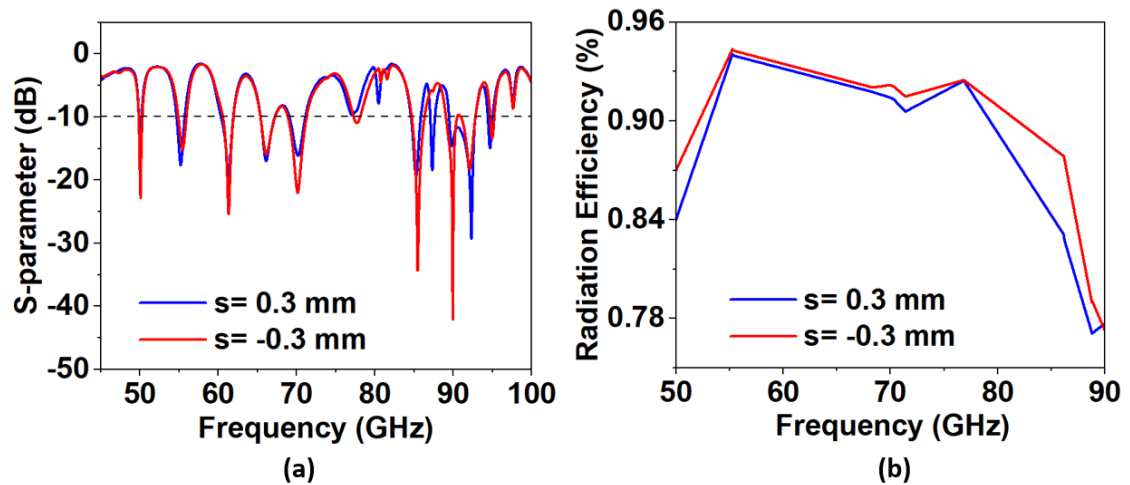
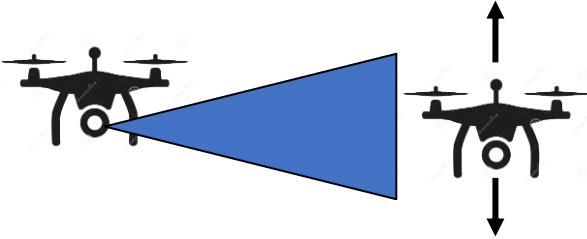

Fig. Antenna Performance

- Peak gain: 9.5 dBi
- Multi Band: 54.4 GHz-55.8 GHz, 60 GHz-61.5 GHz, 63.6 GHz-66.6 GHz, 69 GHz-70.5 GHz, and 83.5 GHz-89 GHz
- Efficiency: > 90 %
- Total BW: 13.5 GHz
- Linear Polarization=> V-band
- CEP=> W-band
- Compact Size: 23.15 mm x 21.4 mm

# Future Work

## Tracking system development



- 1) Dual Circularly polarized arrays for tracking and communication
- 2) Adjustable beam coverage area depending on the target's distance and velocity
- 3) A reconfigurable beamwidth control scheme to achieve the best tradeoff between the array gain and the accuracy of the tracking.

- Design of phased array antenna for variable spacing between elements excited using variable voltage controller-> To **reduce** grating lobe.
- Implementation of hybrid beamforming technique with designed phased array (**>  $\pm 45^\circ$** ).
- Modification of Bow-tie patch element to achieve higher gain (**> 25 dBi**) and circular polarization.
- Using GCPW feeding network to achieve **dual polarization**.
- Substrate analysis-> Efficient, Cost Effective, and Robust-> **To analyze scanning loss and enhance coverage range.**

# Acknowledgement

The presenter wishes to acknowledge the IEEE Vehicular Technology Society for their sponsorship of the Webinar Series on Advanced Air Mobility.



Join IEEE VTS at  
[www.vtsociety.org](http://www.vtsociety.org)

Follow IEEE VTS on social  
media



Website  
[www.vtsociety.org](http://www.vtsociety.org)



Facebook  
[facebook.com/IEEEVTS](https://facebook.com/IEEEVTS)



Twitter  
[@IEEE\\_VTS](https://twitter.com/IEEE_VTS)



LinkedIn  
[www.linkedin.com/company/ieee-vehicular-technology-society](https://www.linkedin.com/company/ieee-vehicular-technology-society)